

RESISTOR NETWORK—SIP RNL SERIES

Features

- High reliability with RUO2 paste
- Miniature, high density packaging
- Combinations of different ohmic values are available

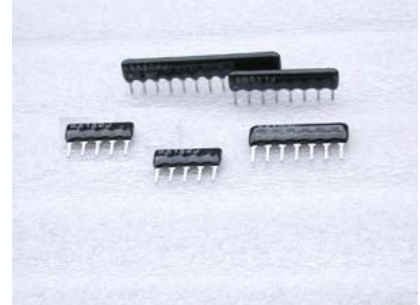

Explanation of Part Number & Ordering Procedure:

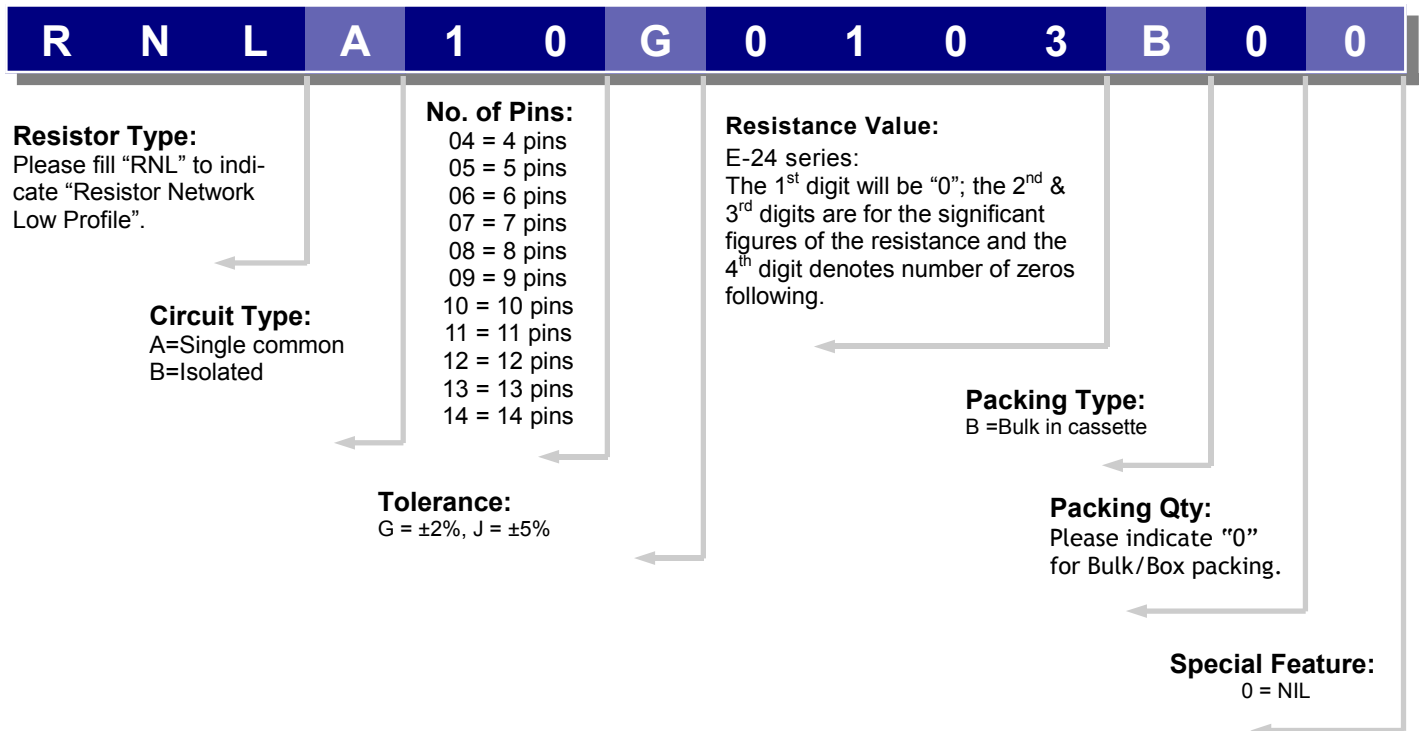

Note:
Ordering procedure (Example: RNL A type 10PIN 2% 10K Ω B/B)

RESISTOR NETWORK—SIP RNL SERIES

Dimension (mm)

Type	L (Max.)	H (Max.)	T (Max.)	C $\begin{matrix} +0.3 \\ -0.2 \end{matrix}$	d ± 0.1	f ± 0.2
4pin	10.2	5.08	2.5	3.2	0.5	2.54
5pin	12.7					
6pin	15.3					
7pin	17.8					
8pin	20.4					
9pin	22.9					
10pin	25.4					
11pin	28.0					
12pin	30.5					
13pin	33.1					
14pin	35.6					

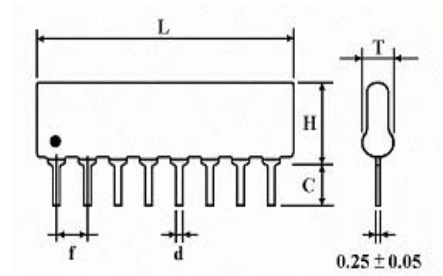

Rating

Power Rating at 70 °C	Max. Working Voltage	Max. Over-load Voltage	Dielectric With-standing Voltage	Resistance Range	Resistance Tolerance	Operating Temp. Range
B Type: 0.2W	100V	150V	200V	R Type: 100Ω~10KΩ	±1% ±2% ±5%	-55°C ~+125°C
Others: 0.125W				Others: 10Ω ~ 1MΩ		

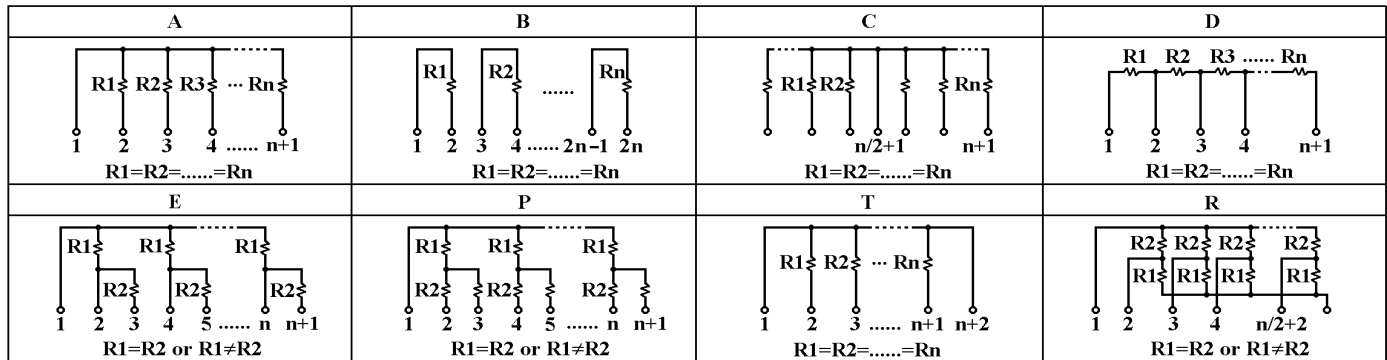

RESISTOR NETWORK—SIP RNL SERIES

Performance Specifications:

Characteristics	Test Methods	Limits															
Temperature coefficient JIS – C – 5202 5.2	-55 °C ~ +125 °C	±200PPM / °C for 50Ω ~ 1MΩ ±250PPM / °C for < 50Ω or > 1MΩ															
Short – time overload JIS – C – 5202 5.5	Rated Voltage x 2.5 for 5 seconds.	± (0.5% + 0.1Ω)															
Insulation resistance JIS – C – 5202 5.6	100V DC for 1 min.	10,000 Mega ohm Min.															
Dielectric withstanding voltage JIS – C – 5202 5.7	Resistors shall be clamped in the trough of a 90 ° metallic V– block and shall be tested at AC potential respectively specified in the above list for 60 + 10 / -0 seconds.	No evidence of flashover mechanical damage, arcing or insulation break down.															
Terminal Strength JIS – C – 5202 6.1	Tensile: 1Kg, 30 seconds. Bending: 500g., 2 Times.	± (0.5% + 0.1 Ω)															
Resistance to Soldering Heat JIS – C – 5202 6.4	350 °C ± 10°C , for 3 seconds.	± (0.5% + 0.1 Ω)															
Solderability JIS – C – 5202 6.5	235°C ± 5°C, 3 seconds.	Covering 95%															
Thermal Shock JIS – C – 5202 7.3	Load V, Room Temp., 30 min. Unload, -55°C, 15 min. Over 2 hrs. in room temp. before measuring.	± (0.5% + 0.1 Ω)															
Temperature cycling JIS – C – 5202 7.4	Resistance change after continuous five cycles for duty cycle specified below: <table border="1" data-bbox="488 1178 1036 1434"> <thead> <tr> <th>Step</th> <th>Temperature</th> <th>Time</th> </tr> </thead> <tbody> <tr> <td>1</td> <td>-55°C±3°C</td> <td>30 mins.</td> </tr> <tr> <td>2</td> <td>Room temp.</td> <td>10– 15 mins.</td> </tr> <tr> <td>3</td> <td>+125 °C±2 °C</td> <td>30 mins.</td> </tr> <tr> <td>4</td> <td>Room temp.</td> <td>10– 15 mins.</td> </tr> </tbody> </table>	Step	Temperature	Time	1	-55°C±3°C	30 mins.	2	Room temp.	10– 15 mins.	3	+125 °C±2 °C	30 mins.	4	Room temp.	10– 15 mins.	± (0.5% + 0.1 Ω)
Step	Temperature	Time															
1	-55°C±3°C	30 mins.															
2	Room temp.	10– 15 mins.															
3	+125 °C±2 °C	30 mins.															
4	Room temp.	10– 15 mins.															
Load life in humidity JIS – C – 5202 7.9	40°C, 90 - 95% RH Rated Voltage for 1,000 hrs. (1.5 hours “on”, 0.5 hour “off”)	± (3.0% + 0.1Ω)															
Load Life JIS – C – 5202 7.10	70°C at Rated Voltage for 1,000 hrs. (1.5 hours “on”, 0.5 hour “off”)	± (3.0% + 0.1 Ω)															