

LAUBE TECHNOLOGY TELECOM RELAYS

<u>CONTACT FORM</u>	<u>CURRENT</u>	<u>PART SERIES</u>	<u>PAGE #'S</u>	
(1A) SPST-NO	1 AMP	HJR4102	8~10	(Link)
(1A) SPST-NO	1 AMP	HJR4102E	11~13	(Link)
(1C) SPDT	2 AMP	TR5V	4~7	(Link)
(1C) SPDT	3 AMP	HJR4102	8~10	(Link)
(1C) SPDT	3 AMP	HJR4102E	11~13	(Link)
(2C) DPDT	1 AMP	HJR1-2C	14~17	(Link)
(2C) DPDT	2 AMP	HJR1-2C	14~17	(Link)

TR5V

SPECIFICATION
 FILE NUMBER: T-08KH101A
 DATE: 2001/11/02



■ Features

Designed for thermostat modem, computer peripherals, video recording and security applications.
 1 form A and 1 form C contact arrangement.
 Low coil power requirement for IC compatibility.
 Terminals arranged on grid pattern.
 Designed for compact, high density mounting.

■ CONTACT DATA

Contact Form	1C	
Contact Material	AgNi+Au	
Contact Ratings	2A 120VAC/2A 24VDC	
Max Switching Voltage	120VAC/60VDC	
Max Switching Current	2A	
Max Switching Power	240VA/48W	
Contact Resistance	100m Ω Max	at 6VDC 1A
Life Expectancy Electrical	100,000	Operations(at 30 Operations/min.)
Mechanical	10,000,000	Operations

■ GENERAL DATA

Insulation Resistance	1000M Ω Min at500VDC	
Dielectric Strength Between Open Contacts	400VAC(for one minute)	
Between Contacts and coil	1000VAC(for one minute)	
Operate Time	4ms Max	
Release Time	3ms Max	
Temperature Range	-25°C~ +55 °C	
Shock Resistance	Operating Extremes	10G
	Damage Limits	100G
Vibration Resistance	10-55Hz Double amplitude of 2.0mm	
Humidity	35%-85%RH	
Weight	Approx. 2.2g	
Safety Standard	UL:E173485	

■ COIL DATA

Nominal Voltage (VDC)	Coil Resistance at 20±10% (Ω)		Max Operate Voltage (VDC)		Min Release Voltage (VDC)	Max Applicable Voltage (VDC)
	0.2w	0.36w	0.2w	0.36w		
3	45	25	2.25	2.1	0.3	3.9
5	125	69.4	3.75	3.5	0.5	6.5
6	180	100	4.5	4.2	0.6	7.8
9	405	225	6.75	6.3	0.9	11.7
12	720	400	9	8.4	1.2	15.6
24	2880	1600	18	16.8	2.4	31.2

TR5V

SPECIFICATION

FILE NUMBER: T-08KH101A

DATE: 2001/11/02

■ Features

Designed for thermostat modem, computer peripherals, video recording and security applications.
 1 form A and 1 form C contact arrangement.
 Low coil power requirement for IC compatibility.
 Terminals arranged on grid pattern.
 Designed for compact, high density mounting.



■ CONTACT DATA

Contact Form	1C	
Contact Material	AgNi+Au	
Contact Ratings	1A 120VAC/1A 24VDC	
Max Switching Voltage	120VAC/60VDC	
Max Switching Current	1A	
Max Switching Power	120VA/30W	
Contact Resistance	100m Ω Max	at 6VDC 1A
Life Expectancy Electrical	100,000	Operations(at 30 Operations/min.)
Mechanical	10,000,000	Operations

■ GENERAL DATA

Insulation Resistance		1000M Ω Min at500VDC
Dielectric Strength Between Open Contacts		400VAC(for one minute)
Between Contacts and coil		1000VAC(for one minute)
Operate Time		4ms Max
Release Time		3ms Max
Temperature Range		-25 °C~+55 °C
Shock Resistance	Operating Extremes	10G
	Damage Limits	100G
Vibration Resistance		10-55Hz Double amplitude of 2.0.mm
Humidity		35%-85%RH
Weight		Approx. 2.2g
Safety Standard		UL:E173485

■ COIL DATA

Nominal Voltage (VDC)	Coil Resistance at20±10% (Ω)	Max Operate Voltage (VDC)	Min Release Voltage (VDC)	Max Applicable Voltage (VDC)
	0.15w	0.15w		
3	60	2.4	0.3	3.9
5	167	4.0	0.5	6.5
6	240	4.8	0.6	7.8
9	540	7.2	0.9	11.7
12	960	9.6	1.2	15.6

■ ORDERING CODE

TR5V D--12VDC-S---Z

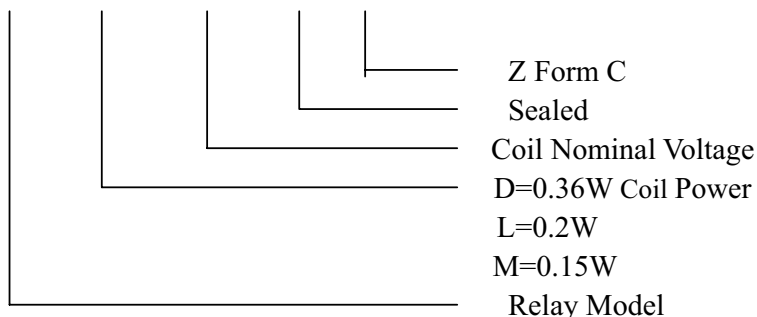

■ OVERALL AND MOUNTING DIMENSIONS

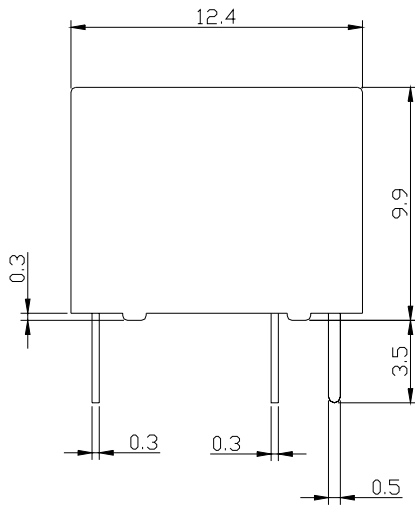

Dimensions

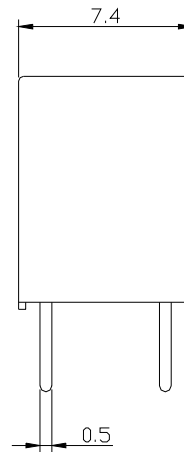

Terminal Arrangement/
Internal Connections
(Bottom view)

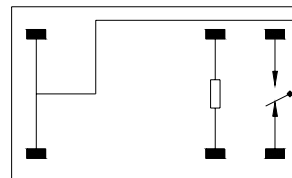
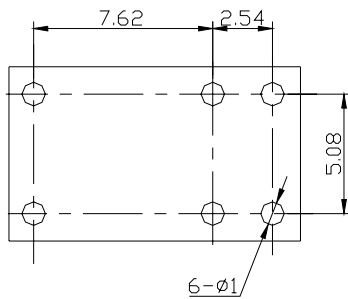

HJR4102

SPECIFICATION

FILE NUMBER: P-08KA201A

DATE: 2001/11/02



■ Features

- Small size and low cost
- DIP standard terminals
- Several sensitivity
- Sealed type available

■ CONTACT DATA

Contact Form	1A/1C	
Contact Material	Ag+Au	AgNi+Au
Contact Ratings	1A 120VAC/24VDC	3A 120VAC/24VDC
Max Switching Voltage	240VAC/60VDC	240VAC/60VDC
Max Switching Current	1A	3A
Max Switching Power	120VA/30W	360VA/90W
Contact Resistance	100m Ω Max	at 6VDC 1A
Life Expectancy Electrical	100, 000	Operations(at 30 Operations/min.)
Mechanical	10, 000, 000	Operations

■ GENERAL DATA

Insulation Resistance		100M Ω Min at 500VDC
Dielectric Strength Between Open Contacts		500VAC(for one minute)
Between Contacts and coil		1000VAC(for one minute)
Operate Time		5ms
Release Time		5ms
Temperature Range		-25°C to+55°C
Shock Resistance	Operating Extremes	10G
	Damage Limits	50G
Vibration Resistance		10-55Hz,1.5mm
Humidity		40-85%
Weight		Approx. 3.5g
Safety Standard		UL E173485

■ COIL DATA

Nominal Voltage (VDC)	Coil Resistance at 20±10%(Ω)			Max Operate Voltage VDC	Min Release Voltage VDC	Max Applicable Voltage VDC
	0.2W	0.36W	0.45W			
3	45	25	20	2.25	0.3	3.9
5	125	70	56	3.75	0.5	6.5
6	180	100	80	4.5	0.6	7.8
9	405	220	180	6.75	0.9	11.7
12	720	400	320	9	1.2	15.6
24	2800	1600	1280	18	2.4	31.2

■ ORDERING CODE

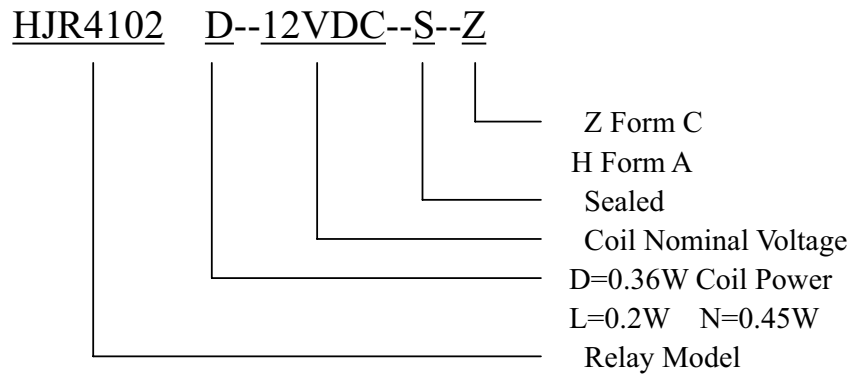

■ OVERALL AND MOUNTING DIMENSIONS

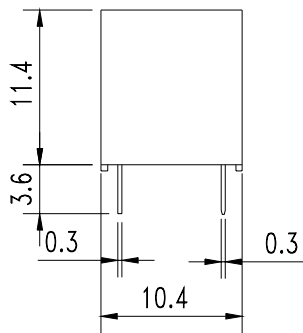

Dimensions

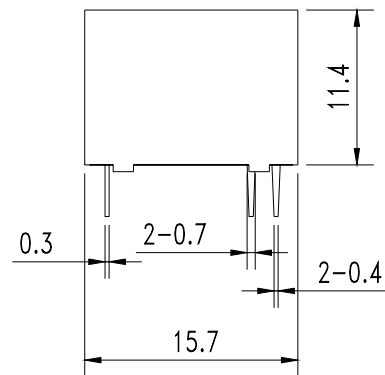

Terminal Arrangement/
Internal Connections
(Bottom view)

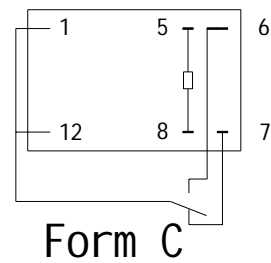
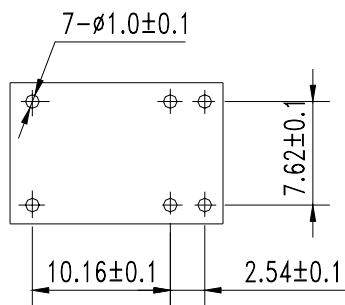

Form C

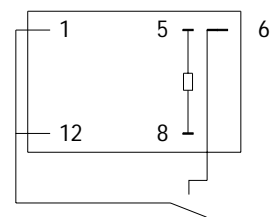

Form A

HJR4102E

SPECIFICATION

FILE NUMBER: P-08KA301A

DATE: 2001/11/02



■ Features

- Small size and low cost
- DIP standard terminals
- Several sensitivity
- Sealed type available

■ CONTACT DATA

Contact Form	1A/1C	
Contact Material	Ag+Au	AgNi+Au
Contact Ratings	1A 120VAC/24VDC	3A 120VAC/30VDC
Max Switching Voltage	240VAC/60VDC	240VAC/60VDC
Max Switching Current	1A	3A
Max Switching Power	120VA/30W	360VA/90W
Contact Resistance	100m Ω Max	at 6VDC 1A
Life Expectancy Electrical	100,000	Operations(at 30 Operations/min.)
Mechanical	10,000,000	Operations

■ GENERAL DATA

Insulation Resistance		100M Ω Min at 500VDC
Dielectric Strength Between Open Contacts		500VAC(for one minute)
Between Contacts and coil		1000VAC(for one minute)
Operate Time		5ms
Release Time		5ms
Temperature Range		-25°C to+55 °C
Shock Resistance	Operating Extremes	10G
	Damage Limits	50G
Vibration Resistance		10-55Hz,1.5mm
Humidity		40-85%
Weight		Approx 3.5g
Safety Standard		UL E173485

■ COIL DATA

Nominal Voltage (VDC)	Coil Resistance at 20±10%(Ω)			Max Operate Voltage VDC	Min Release Voltage VDC	Max Applicable Voltage VDC
	0.2W	0.36W	0.45W			
3	45	25	20	2.25	0.3	3.9
5	125	70	56	3.75	0.5	6.5
6	180	100	80	4.5	0.6	7.8
9	405	220	180	6.75	0.9	11.7
12	720	400	320	9	1.2	15.6
24	2800	1600	1280	18	2.4	31.2

■ ORDERING CODE

HJR4102E D--12VDC--S--Z

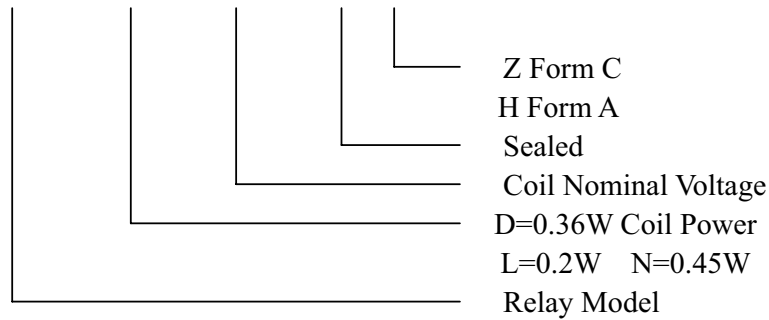

■ OVERALL AND MOUNTING DIMENSIONS

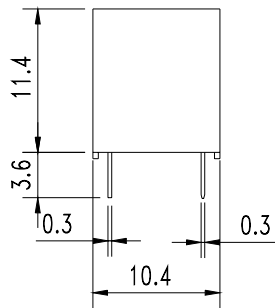

Dimensions

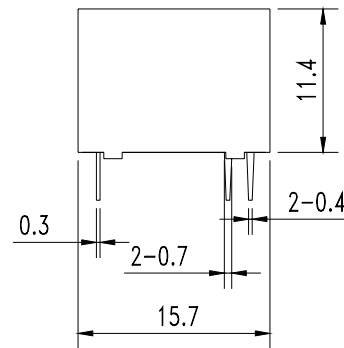

Terminal Arrangement/
Internal Connections
(Bottom view)

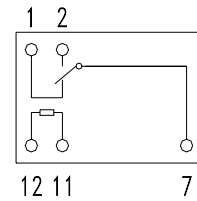
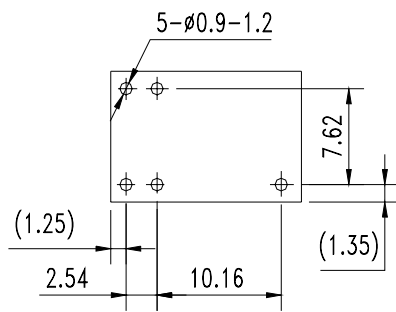

FormC

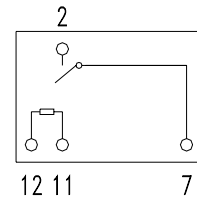

FormA

HJR1-2C

SPECIFICATION

FILE NUMBER: P-08KA401A

DATE: 2001/11/02



■ Features

- DPDT configuration
- High sensitivity
- DIP standard terminals
- Sealed version

■ CONTACT DATA

Contact Form	2C	
Contact Material	Ag+Au	AgNi+Au
Contact Ratings	0.5A 120VAC/1A24VDC	1A120VAC/2A 24VDC
Max Switching Voltage	240VAC/60VDC	
Max Switching Current	1A	2A
Max Switching Power	60VA/30W	120VA/60W
Contact Resistance	100m Ω Max	at 6VDC 1A
Life Expectancy Electrical	100,000	Operations(at 30 Operations/min.)
Mechanical	10,000,000	Operations

■ GENERAL DATA

Insulation Resistance	100M Ω Min at 500VDC	
Dielectric Strength Between Open Contacts	500/750VAC (for one minute/sec)	
Between Contacts and coil	1000/1250VAC (for one minute/sec)	
Operate Time	6ms	
Release Time	4ms	
Temperature Range	-30°C to+70°C	
Shock Resistance	Operating Extremes	10G
	Damage Limits	50G
Vibration Resistance	10-55Hz,1.5mm	
Humidity	40-85%	
Weight	Approx.5g	
Safety Standard	UL:E173485 cUL. TUV:R9859574	

■ COIL DATA

Nominal Voltage (VDC)	Coil Resistance at 20±10%(Ω)			Max Operate Voltage VDC	Min Release Voltage VDC	Max Applicable Voltage VDC
	0.2W	0.36W	0.45W			
3	45	25	20	2.25	0.3	3.9
5	125	70	56	3.75	0.5	6.5
6	180	100	80	4.5	0.6	7.8
9	405	220	180	6.75	0.9	11.7
12	720	400	320	9	1.2	15.6
24	2800	1600	1280	18	2.4	31.2
48		6400±15%	5100±15%	36	4.8	62.4

HJR1-2C

SPECIFICATION

FILE NUMBER: P-08KA401A

DATE: 2001/11/02



■ Features

- DPDT configuration
- High sensitivity
- DIP standard terminals
- Sealed version

■ CONTACT DATA

Contact Form	2C	
Contact Material	Ag+Au	
Contact Ratings	0.5A 120VAC	1A 24VDC
Max Switching Voltage	240VAC/60VDC	
Max Switching Current	2A	
Max Switching Power	240VA/60W	
Contact Resistance	100m Ω Max	at 6VDC 1A
Life Expectancy Electrical	100,000	Operations(at 30 Operations/min.)
Mechanical	10,000,000	Operations

■ GENERAL DATA

Insulation Resistance		100M Ω Min at 500VDC
Dielectric Strength Between Open Contacts		500(for one minute)
Between Contacts and coil		1000(for one minute)
Operate Time		8ms
Release Time		4ms
Temperature Range		-30 °C to+70 °C
Shock Resistance	Operating Extremes	10G
	Damage Limits	50G
Vibration Resistance		10-55Hz,1.5mm
Humidity		40-85%
Weight		Approx.5g
Safety Standard		UL:E173485 cUL. TUV:R9859574

■ COIL DATA

Nominal Voltage (VDC)	Coil Resistance at 20±10%(Ω)	Max Operate Voltage VDC	Min Release Voltage VDC	Max Applicable Voltage VDC
	0.15W			
3	60	2.4	0.15	3.9
5	167	4	0.25	6.5
6	240	4.8	0.3	7.8
9	540	7.2	0.45	11.7
12	960	9.6	0.6	15.6

■ ORDERING CODE

HJR1-2C D--12VDC

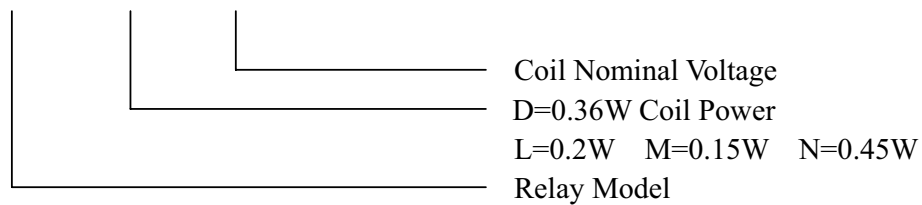

OVERALL AND MOUNTING DIMENSIONS

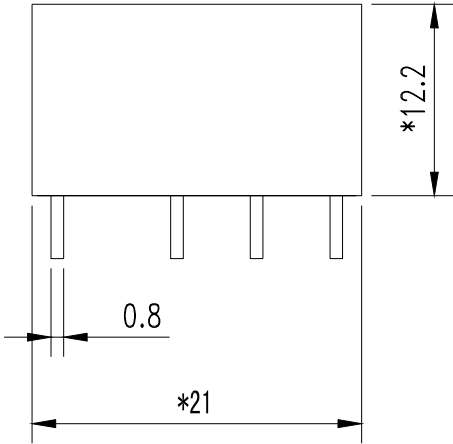
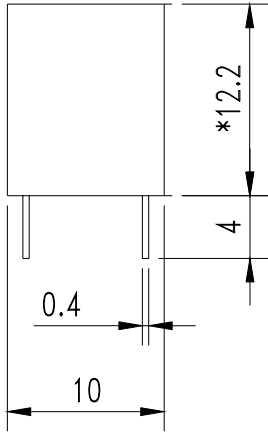

*(1)11.8 x20.3 (2)12.2x21

Dimensions

Terminal Arrangement/
Internal Connections
(Bottom view)

