

Series	Diameter (mm)	Height (mm)	Impedance ( $\Omega$ )	SPL (dB)	Rated Power Input	Max. Power Input (W)	Fundamental Frequency <i>f</i> <sub>o</sub> (Hz.)	Frequency Range <i>f</i> <sub>o</sub> - (Hz)	Frame	Terminal	Page No.
<b>SR13A</b>											65
Speaker	13.3	3.3	8 ± 10%	83 ± 3	0.20W	0.30	850	<i>f</i> <sub>o</sub> - 15K	METAL	PLATE	
Receiver			8 ± 10%	126 ± 3	280mV	0.10					
<b>SR15A</b>											65
Speaker	15.0	3.8	8 ± 15%	88 ± 3	0.20W	0.50	850	650 - 10K	ABS	NIL	
Receiver			32 ± 15%	107 ± 3	0.001 W	0.06					

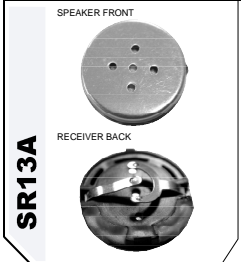

COLOUR	HOUSING	TERMINAL
SILVER	METAL	NIL

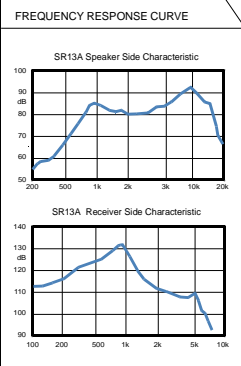

**ELECTRICAL SPECIFICATIONS**

Model No.	SR13A33	MYLAR SPEAKER	DYNAMIC RECEIVER
AC Impedance at 1KHz.	(Ω)	8 ± 10%	8 ± 10%
SPL	(dB)	83 ± 3 @ 0.2W / 10cm	126 ± 3 at 1KHz.
Rated Power Input		0.20 W	280 mV
Max. Power Input	(W)	0.30	0.10
Fundamental Frequency	(Hz.)	850 ± 20% (at 1.0V)	
Frequency Range	(Hz.)	f <sub>o</sub> - 15K	300 - 4000
Weight	(g)	1	1

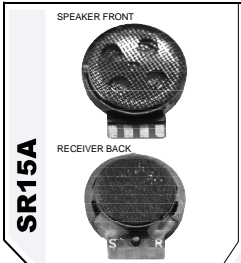
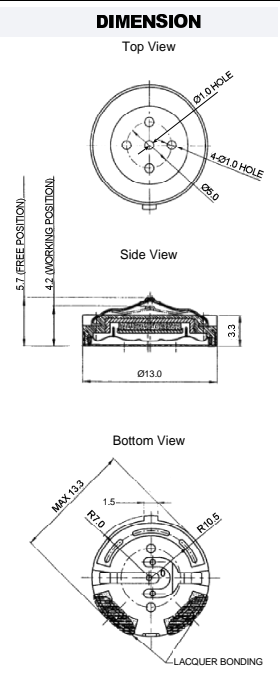
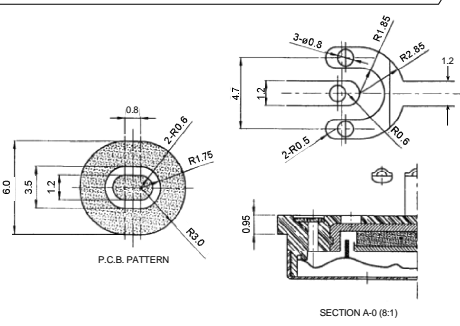

COLOUR	HOUSING	TERMINAL
BLACK	ABS	NIL



**ELECTRICAL SPECIFICATIONS**

Model No.	SR15A38	MYLAR SPEAKER	DYNAMIC RECEIVER
AC Impedance at 1KHz.	(Ω)	8 ± 15%	32 ± 15%
SPL	(dB)	88 ± 3 @ 0.2W / 10cm	107 ± 3 at 1KHz.
Rated Power Input		0.20 W	0.001 mV
Max. Power Input	(W)	0.50	0.06
Fundamental Frequency	(Hz.)	850 ± 20% (at 1.0V)	
Frequency Range	(Hz.)	650 - 10K	300 - 4000
Weight	(g)	1.35	1.35

